

Petr Klán

Estimation of polynomial roots by continued fractions

Kybernetika, Vol. 21 (1985), No. 6, 457--469

Persistent URL: <http://dml.cz/dmlcz/125887>

Terms of use:

© Institute of Information Theory and Automation AS CR, 1985

Institute of Mathematics of the Academy of Sciences of the Czech Republic provides access to digitized documents strictly for personal use. Each copy of any part of this document must contain these

Terms of use.



This paper has been digitized, optimized for electronic delivery and stamped with digital signature within the project *DML-CZ: The Czech Digital Mathematics Library*
<http://project.dml.cz>

ESTIMATION OF POLYNOMIAL ROOTS BY CONTINUED FRACTIONS

PETR KLÁN

The article describes a method of polynomial root solving with Viskovatoff's decomposition (analytic continued fraction theory) and with characteristic root locus construction.

1. INTRODUCTION

One of the ways to describe dynamical characteristics of the system is the s -transfer function, which belongs to the class of the so-called external descriptions and from the mathematical point of view it represents a rational function. Decomposition into the partial fractions (sum of exponential functions in the time domain) is based on the knowledge of the roots of the polynomial defined by the denominator of the transfer function; from their location it is possible to deduce dynamical characteristics, system stability, etc. The numerator roots position indicates the phase characteristic of the system. There exists a large number of successful methods for calculating the polynomial roots (for instance Lehmer-Shur, Bairstow, Graef, Bernoullia, Newton-Raphson and many others).

The method described here is based on Viskovatoff's decomposition of a rational function, and makes use of the continued fraction theory and the characteristic root loci construction proposed by Evans. In the second part of this paper two existing methods are discussed for approximate finding of the polynomial roots through the construction of characteristic root loci. Each of them is illustrated by a simple solved example. In the third part a short introduction to the analytic theory of continued fractions is given. It contains necessary conclusions for the proposed method and is also completed by a solved example. In the fourth part the general algorithm is given and a sample solution is explored. The final part provides a comparison with other methods, the possibility of algorithmization, characteristic root loci construction on microcomputers, etc.

Notation

s	– Laplace transform complex variable
$a_i, b_i, c_i, p_i; i = 0, 1, 2, \dots$	– real or complex constants
$P(s)$	– complex polynomial
$W_i(s), G_i(s); i = 1, 2, \dots$	– rational functions of the complex variable s
$K_q; q = 1, 2, \dots$	– gain constants
$s_i, r_i; i = 1, 2, 3$	– polynomial roots
x	– real or complex variable
$\alpha_{i,j}; i = 0, 1, \dots, j = 0, 1, \dots$	– real constants
q, m, n, i, j	– integer number
$f_q(a_i, b_j); q = 0, 1, \dots$ $i = 0, 1, \dots$ $j = 0, 1, \dots$	– real functions of two variables
j	– imaginary unit

2. BRIEF REVIEW OF TWO CURRENTLY USED METHODS

Both methods presented here use the construction of characteristic root locus for finding the polynomial root positions in the complex plane, proposed by Evans.

2.1. First method

This method uses Horner scheme of polynomial computing. It will be explained on an example of the fourth order polynomial. Let us have the polynomial

$$P(s) = s^4 + as^3 + bs^2 + cs + d$$

It is possible to rewrite this polynomial as

$$P(s) = \{[(s + a)s + b]s + c\}s + d$$

The expression in the brackets is solved first as a quadratic equation, then the others by characteristic root loci construction for known gain constants c, d

$$(s + a)s + b = (s + r_1)(s + r_2)$$

Expression in the braces can now be rewritten as

$$(s + r_1)(s + r_2)s + c$$

The roots of this expression will be determined by constructing the characteristic root locus for the function

$$W_1(s) = \frac{k}{s(s + r_1)(s + r_2)}, \quad k = c$$

for $k \in (0, \infty)$ and on these three branches, the points are selected that satisfy $k = c$. At this moment three roots r'_1, r'_2, r'_3 are known.

Final polynomial $P(s)$ has the form

$$P(s) = (s + r'_1)(s + r'_2)(s + r'_3)s + d$$

and the last task is to construct the characteristic root locus for the function $W_2(s)$

$$W_2(s) = \frac{k}{s(s + r'_1)(s + r'_2)(s + r'_3)}, \quad k = d$$

and from the points for $k = d$ the roots of the polynomial $P(s)$ can be obtained. A certain disadvantage is the fact that it is necessary to assign the corresponding gain of the open loop to the points of the characteristic roots loci. This method is suitable for polynomials of order $n \leq 5$.

Example.

$$P(s) = s^3 + 25.5s^2 + 685s + 8150$$

Rewritten as

$$P(s) = [(s + 25.5)s + 685]s + 8150$$

For determining the roots in the brackets it is necessary to solve the quadratic equation

$$s^2 + 25.5s + 685 = 0$$

the solution of which is $r_{1,2} = -12.75 \pm j 22.85$.

Rewrite $P(s)$ in the form

$$P(s) = (s + 12.75 - j 22.85)(s + 12.75 + j 22.85)s + 8150$$

that

$$W(s) = \frac{k}{s(s + 12.75 - j 22.85)(s + 12.75 + j 22.85)}$$

By constructing the characteristic root locus for $k = 8150$ we obtain three roots, which are also roots of the polynomial $P(s)$, $s_{1,2} = -5 \pm j 22.4$; $s_3 = -15.5$.

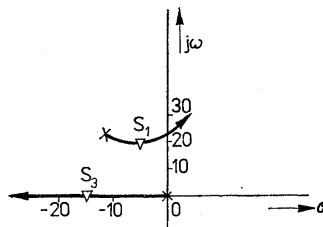

Fig. 1. Characteristic root locus for function $W(s)$.

2.2. Second method

This method seems better than the previous one, because it does not require to determine the gain corresponding to the characteristic root loci. It is suitable for polynomials of order $n \leq 5$, too.

Let us have polynomial

$$P(s) = s^n + a_1 s^{n-1} + \dots + a_n = 0$$

By rewriting it to the form

$$W_1(s) = \frac{a_{n-2} \left(s^2 + \frac{a_{n-1}}{a_{n-2}} s + \frac{a_n}{a_{n-2}} \right)}{s^3 (s^{n-3} + a_1 s^{n-4} + \dots + a_{n-3})} = -1$$

and

$$W_2(s) = \frac{a_{n-1} \left(s + \frac{a_n}{a_{n-1}} \right)}{s^2 (s^{n-2} + a_1 s^{n-3} + \dots + a_{n-2})} = -1$$

it is possible to find the characteristic root loci of functions $W_1(s)$ and $W_2(s)$. Roots of the polynomial $P(s)$ lie in the intersections of single branches.

Example.

$$P(s) = s^4 + 15s^3 + 55s^2 + 245s + 204$$

$$W_1(s) = \frac{k_1 \left(s^2 + \frac{245}{55} s + \frac{204}{55} \right)}{s^3 (s + 15)}$$

$$W_2(s) = \frac{k_2 \left(s + \frac{204}{245} \right)}{s^2 (s^2 + 15s + 55)} = \frac{k_2 (s + 0.83)}{s^2 (s + 6.4) (s + 8.61)}$$

$$k_1 = a_{n-2}, k_2 = a_{n-1}.$$

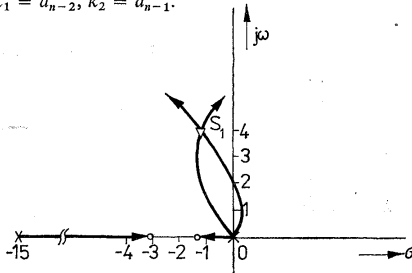

Fig. 2. Characteristic root locus for $W_1(s)$.

It can be seen that $s_{1,2} = -1 \pm j 4$ and it is a simple task to find the intersection of two root loci for $s_3 = -1$, $s_4 = -12$ by using W_2 .

3. INTRODUCTION TO THE THEORY OF CONTINUED FRACTIONS

3.1. Continued fraction

The expression

$$b_0 + \frac{a_1}{b_1 + \frac{a_2}{b_2 + \frac{a_3}{b_3 + \dots + \frac{a_n}{b_n + \dots}}}}$$

is called a continued fraction. This form is very inconvenient and we shall rather use the notation introduced by Rogers [1]

$$b_0 - \frac{a_1}{b_1 + \frac{a_2}{b_2 + \dots + \frac{a_n}{b_n + \dots}}}$$

The continued fraction which has a finite number of elements is called finite.

3.2. Identical transformation

The basic identical transformation of a continued fraction is

$$\begin{aligned} b_0 + \frac{a_1}{b_1 + \frac{a_2}{b_2 + \dots + \frac{a_n}{b_n}}} &= \\ = b_0 + \frac{p_1 a_1}{p_1 b_1 + \frac{p_1 p_2 a_2}{p_2 b_2 + \dots + \frac{p_{n-1} p_n a_n}{p_n b_n}}}, \end{aligned}$$

where $p_i, i = 1, 2, \dots, n$ is an arbitrary constant.

3.3. Viskovatoff's method

A rational function can be transformed into a finite continued fraction as follows:

$$\begin{aligned} f(x) &= \frac{\alpha_{10} + \alpha_{11}x + \alpha_{12}x^2 + \alpha_{13}x^3 \dots}{\alpha_{00} + \alpha_{01}x + \alpha_{02}x^2 + \alpha_{03}x^3 \dots} = \\ &= \frac{\alpha_{10}}{\alpha_{00} + \frac{\alpha_{20}x}{\alpha_{10} + \frac{\alpha_{30}x}{\alpha_{20} + \dots}}}, \end{aligned}$$

where

$$\alpha_{m,n} = \alpha_{m-1,0} \cdot \alpha_{m-2,n+1} - \alpha_{m-2,0} \cdot \alpha_{m-1,n+1}$$

The coefficients can easily be computed using the following scheme.

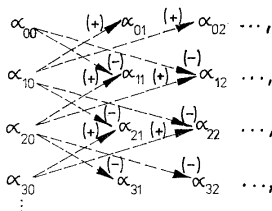

Fig. 3. Expansion scheme.

Comment. If $\alpha_{k,0} = 0$ has been obtained during the computation of the coefficients $\alpha_{m,n}$, then $(k+2)$ th column of the scheme is created by a single left shift of the $(k+1)$ th column, the $(k+3)$ th column is computed by using the expansion scheme from the $(k+2)$ th and k th columns, the $(k+4)$ th by using of $(k+3)$ th and $(k+2)$ th columns etc. Hence the expansion of the continued fraction will have the form

$$f(x) = \frac{\alpha_{10}}{\alpha_{00} + \alpha_{10}} + \frac{\alpha_{20}x}{\alpha_{00} + \alpha_{10} + \dots + \alpha_{k-2,0} + \alpha_{k-1,0}} + \frac{\alpha_{k-1,0}x}{\alpha_{00} + \alpha_{10} + \dots + \alpha_{k-2,0} + \alpha_{k-1,0}} + \frac{\alpha_{k1}x^2}{\alpha_{00} + \alpha_{10} + \dots + \alpha_{k-2,0} + \alpha_{k-1,0}} + \frac{\alpha'_{k+1,1}x}{\alpha_{k1}} + \frac{\alpha'_{k+2,1}x}{\alpha'_{k+1,1}} + \dots$$

Example.

$$G(x) = \frac{x^2 + 8x + 25}{x^4 + 15x^3 + 55x^2 + 245x + 204}$$

Expansion into the finite continued fraction:

20.4	24.5	5.5	1.5	0.1
2.5	0.8	0.1	0	
44.93	11.71	3.75	0.25	
6.669	-4.882	-0.625		
297.44	53.09	1.6673		
-1806.17	-197.0			
-37 287.42	-3011.34			
+1907 390.4				
-5743795975				

$$G(x) = \frac{2.5}{20.4 + \frac{44.93x}{2.5} + \frac{6.669x}{44.93} + \frac{297.44x}{6.669} - \frac{1806.17x}{297.44} - \frac{37\ 287.42x}{-1\ 806.17} + \frac{1\ 907\ 390.4x}{-37\ 287.42} - \frac{5\ 743\ 795\ 975x}{1\ 907\ 390.4} - \dots$$

Identical transformation (rounded):

$$G(x) = \frac{2.500}{20.40} + \frac{44.93x}{2.500} + \frac{6.669x}{44.93} + \frac{297.4x}{6.669} - \\ - \frac{18.06x}{2.974} + \frac{3.729x}{18.06} + \frac{19.07x}{37.29} + \frac{5.7438x}{1.907}$$

4. A NEW METHOD BASED ON CONTINUED FRACTIONS

Let a rational transfer function be given. By applying Viskovatoff's method one can provide an expansion into the finite continued fraction with known coefficients.

$$G(s) = K \frac{s^m + b_1 s^{m-1} + \dots + b_m}{s^n + a_1 s^{n-1} + \dots + a_n} = K \left(\frac{b_m}{a_n} + \frac{f_1(a_i, b_j) s}{f'_1(a_i, b_j)} + \dots + \frac{f_q(a_i, b_j) s}{f'_q(a_i, b_j)} \right)$$

$m < n$, $i = 0, 1, \dots, n$ and $j = 0, 1, \dots, m$.

Let us sum single elements of the continued fraction from the end

$$G_q(s) = \frac{f_q(a_i, b_j) s}{f'_q(a_i, b_j)}$$

$$G_{q-1}(s) = \frac{f_{q-1}(a_i, b_j) s}{f'_{q-1}(a_i, b_j) + \frac{f_q(a_i, b_j) s}{f'_q(a_i, b_j)}} =$$

$$= \frac{f_{q-1}(a_i, b_j) f'_q(a_i, b_j) s}{f'_{q-1}(a_i, b_j) f'_q(a_i, b_j) + f_q(a_i, b_j) s} = K_{q-1} \frac{C_{q-1} s}{C_{q-1} + s},$$

$$C_{q-1} = \frac{f_{q-1}(a_i, b_j) f'_q(a_i, b_j)}{f_q(a_i, b_j)}$$

$$C'_{q-1} = \frac{f'_{q-1}(a_i, b_j) f'_q(a_i, b_j)}{f_q(a_i, b_j)}$$

$$K_{q-1} = \frac{1}{f_q(a_i, b_j)}$$

$$G_{q-2}(s) = \frac{f_{q-2}(a_i, b_j) s}{f'_{q-2}(a_i, b_j) + G_{q-1}(s)} =$$

$$= \frac{f_{q-2}(a_i, b_j) s}{f'_{q-2}(a_i, b_j) + \frac{C_{q-1} s}{C_{q-1} + s}} = \frac{f_{q-2}(a_i, b_j) s (C'_{q-1} + s)}{f'_{q-2}(a_i, b_j) (C'_{q-1} + s) + C_{q-1} s}$$

Transfers (rational functions) $G_q(s), G_{q-1}(s), \dots, G_1(s)$ are called partial transfers, $G_1(s) = G(s)$. It is always possible to obtain the expressions through the identical transformation of continued fraction (conditional equation is $\arg f_i(s) = \pm 2k\pi$, $k = 0, 1, \dots$), although it is not sure that given partial transfers are physically realizable (higher degree of the numerator compared to the degree of the denominator). Similar rules govern the characteristic root loci construction, for instance the root locus comes from the poles for the gain $K \rightarrow 0$

$$1 + G(s) = 1 + K \frac{\prod_i (s + a_i)}{\prod_i (s + a'_i)} = 0$$

$$\prod_i (s + a'_i) + k \prod_i (s + a_i) = 0$$

If $K \rightarrow 0$, then the roots of the equation are the same as poles $- a'_i$.

At the beginning we fix the partial transfer poles by a simple method (e.g. quadratic equations solving, polynomial division).

The general partial transfer will have the form

$$G_q(s) = K_q \frac{(s + a_1)(s + a_2) \dots (s + a_t)}{(s + a'_1)(s + a'_2) \dots (s + a'_\mu)}$$

where $\mu \geq t$

$$\begin{aligned} G_{q-1}(s) &= \frac{f_{q-1}(a_i, b_j) s}{f'_{q-1}(a_i, b_j) + G_{q-1}(s)} = \\ &= \frac{f_{q-1}(a_i, b_j) s(s + a'_1)(s + a'_2) \dots (s + a'_\mu)}{f'_{q-1}(a_i, b_j)(s + a'_1) \dots (s + a'_\mu) + K_q(s + a_1) \dots (s + a_t)} \end{aligned}$$

and will lead to the characteristic equation

$$G_{q-1}(s) + f'_{q-1}(a_i, b_j) = 0.$$

During the computation of the continued fraction in reversed order, there can occur expressions such as

$$\frac{c_1 s}{c'_1 + f_1(s)} \quad \text{or} \quad \frac{c_2 s^2}{c'_2 + f'_1(s)}$$

which represent the transform of once or twice differentiated control error in the closed control loop while $f_1(s), f'_1(s)$ are already expanded.

Through

$$\frac{\frac{c_1 s}{c'_1}}{1 + \frac{1}{c'_1} f_1(s)} \quad \text{or} \quad \frac{\frac{c_2 s^2}{c'_2}}{1 + \frac{1}{c'_2} f'_1(s)}$$

the control loop transfer denominator will be obtained and the poles position depends on the open loop gain.

Changes of the control loop parameters (in this case it means changes of the constants c_1 , c_2 in the partial transfers and the open-loop gain too) cause changes of the closed control loop poles in the complex plane. Construction of root locus proposed by Evans is equivalent to the solution of the characteristic equations too.

$$1 + \frac{1}{c_1} f_1(s) = 0 \quad \text{or} \quad 1 + \frac{1}{c_2} f_2(s) = 0.$$

This equation results in the conditional equations

$$\begin{aligned} |f_1(s)| &= c_1 \quad \text{or} \quad |f_2(s)| = c_2 \\ \arg f_1(s) &= \pm\pi(1 + 2k) \quad \arg f_2(s) = \pm\pi(1 + 2k) \quad k = 0, 1, 2, \dots \end{aligned}$$

The desired expansion will be completed by the repetition of the given principle.

Example. Transfer $G(s)$ and Viskovatoff's decomposition of $G(s)$

$$\begin{aligned} G(s) &= \frac{s^2 + 8s + 25}{s^4 + 15s^3 + 55s^2 + 245s + 204} = \\ &= \frac{2.500}{20.40} + \frac{44.93s}{2.500} + \frac{6.669s}{44.93} + \frac{297.4s}{6.669} - \\ &\quad - \frac{18.06s}{2.974} + \frac{3.729s}{18.06} + \frac{19.07s}{37.29} + \frac{5.7438s}{1.907} \end{aligned}$$

Partial transfers computation and root loci design

$$\begin{aligned} G_8(s) &= \frac{5.7438s}{1.907} \\ G_7(s) &= 37.29 + \frac{5.7438s}{1.907} = \frac{19.07s}{37.29 + 3.011s} \\ G_6(s) &= \frac{3.729s}{18.06 + G_7(s)} = \frac{3.729s(3.729 + 0.3011s)}{67.35 + 7.346s} \\ G_5(s) &= \frac{18.06s}{2.974 + G_6(s)} = \frac{18.06s(67.35 - 7.346s)}{200.3 + 35.75s + 1.1235s^2} \\ G_4(s) &= \frac{297.4s}{6.669 - G_5(s)} = \frac{297.4s(0.1123s^2 + 3.575s + 20.03)}{-12.52s^2 - 97.80s + 133.6} = \\ &= \frac{2.662s(s + 24.58)(s + 7.257)}{(-1)(s + 9)(s - 1, 2)} \end{aligned}$$

$$G_3(s) = \frac{6.669s}{44.93 + G_4(s)} = \frac{-8.349s^3 - 65.22s^2 + 89.091s}{3.3394s^3 + 50.1s^2 + 156.43s + 600.2}$$

By roots loci design

$$G_4(s) = 44.93, \quad |G_4(s)| = \frac{44.93}{2.662}, \quad \arg G_4(s) = \pm\pi 2k, \quad k = 0, 1, \dots$$

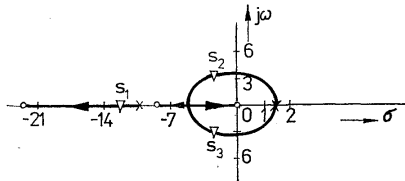

Fig. 4. Roots loci design for $G_4(s)$.

$$s_1 = -12.4 \quad s_{2,3} = -1.25 \pm j 3.74.$$

$$G_3(s) = 2.46 \frac{s(s+9)(-s+1.2)}{(s+12.4)(s+1.25+j3.74)(s+1.25-j3.74)}$$

$$G_2(s) = \frac{44.93s}{2.5 + G_3(s)} = 2.5 \frac{s(s+12.4)(s+1.25+j3.74)(s+1.25-j3.74)}{(s+4+j3)(s+4-j3)}$$

$$G_1(s) = G(s) = \frac{2.5}{20.4 + G_2(s)}$$

$$G_2(s) = -20.4, \quad |G_2(s)| = \frac{-20.4}{2.5}, \quad \arg G_2(s) = \pm\pi(1+2k), \quad k = 0, 1, \dots$$

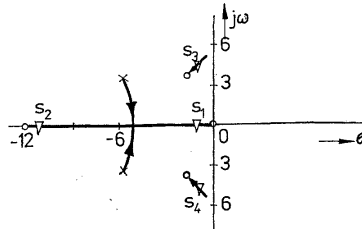

Fig. 5. Roots loci design for $G_2(s)$.

$$s_1 = -1, \quad s_2 = -12, \quad s_{3,4} = -1 \pm j 4.$$

5. CONCLUSION

By application of Viskovatoff's decomposition to the transfer function $G(s)$ we have obtained a sequence of partial transfers (partial sums of continued fractions) that are in fact derived from the basic transfer function, realized through feedbacks and differentiation. The situation is shown in Fig. 6.

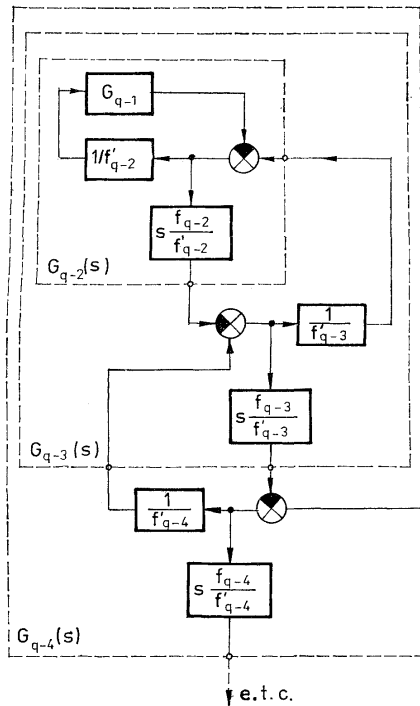

Fig. 6. Decomposition of transfer $G(s)$ realized through feedbacks and differentiation.

If the degree of the partial transfer numerator is higher than the degree of the denominator, it is possible to obtain several systems coupled in parallel by dividing the polynomials. They are of the type K , K_1s , K_2s , K_2s^2 , ..., $G_R(s)$ where the last system is strictly proper.

Viskovatoff's decomposition is suitable for an approximate computation of the roots, for more accuracy a larger number of decimal digits is necessary. For application of this method, it is suitable to use the mathematical coprocessor 8087 in the

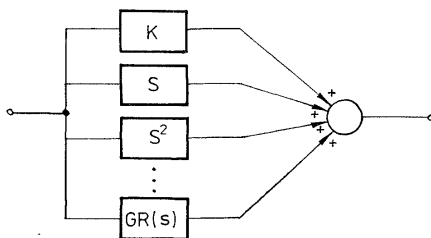

Fig. 7. Decomposition of an improper system.

cooperation with the processor 8086. Algorithmization seems to be quite simple. On the other hand it is much more complicated to algorithmize the characteristic root loci construction. In the Institute of Information Theory and Automation of the Czechoslovak Academy of Sciences, there is a program for root loci plotting that is based on the known transfer coefficients. The second discussed program takes a considerable size of memory. The preconstruction of characteristic root loci in conjunction with e.g. quadratic equation solving, polynomial division etc. is useful, because it is quite simple to estimate the real roots from the definition.

By comparison with the two other methods mentioned above, this method shows one great advantage — the possibility of simplifying the Laplace transfer function by continued fraction expansion. The simplified form of the s -transfer function is obtained from Viskovatoff's decomposition of $G(s)$ by keeping the first several quotients in the continued fraction expansion and discarding the others [2].

Consider a typical system as follows:

$$G(s) = \frac{b_1s^4 + b_2s^3 + b_3s^2 + b_4s + b_5}{a_1s^8 + a_2s^7 + a_3s^6 + a_4s^5 + a_5s^4 + a_6s^3 + a_7s^2 + a_8s + a_9}$$

where

$a_1 = 1.7273 \text{ E-11}$	$a_8 = 5.71677 \text{ E-1}$
$a_2 = 1.3347 \text{ E-8}$	$a_9 = 1.0$
$a_3 = 2.09672 \text{ E-6}$	$b_1 = 1.16074 \text{ E-8}$
$a_4 = 1.09963 \text{ E-4}$	$b_2 = 9.20121 \text{ E-6}$
$a_5 = 2.89073 \text{ E-3}$	$b_3 = 1.46464 \text{ E-3}$
$a_6 = 4.28268 \text{ E-2}$	$b_4 = 7.16799 \text{ E-2}$
$a_7 = 3.28969 \text{ E-1}$	$b_5 = 1.0$

for which a second-order simplified model is required. We arrange the polynomials of the function in the ascending order first and then expand into the continued fraction (Cauer first form).

$$G(s) = \frac{1}{1.0 + \frac{2.0}{s + \frac{1}{-0.8571 + \frac{1}{-1.9973 + \frac{1}{s + \dots}}}}}$$

The continued fraction described above has sixteen quotients. If a simplified model of second order is needed simply keep the first four quotients and discard the others, then plot the root loci of the truncated continued fraction.

(Finally we have:

$$G(s) \approx \frac{0.0027s + 3.42377}{s^2 + 1.71459s + 3.42377})$$

(Received July 12, 1984.)

REFERENCES

- [1] H. S. Wall: *Analytic Theory of Continued Fraction*. Van Nostrand, Princeton, N. J. 1948.
- [2] C. F. Chen and L. S. Shieh: An algebraic method for control system design. *Internat. J. Control* 5 (1970), 11, 717–739.
- [3] E. T. Uberman: *Metod korněvogo godografa v teorii avtomatičeskogo upravljenija*. GEI, Moskva 1963.
- [4] W. R. Evans: *Control System Dynamics*. McGraw-Hill, New York 1954.

Ing. Petr Klán, Ústav teorie informace a automatizace ČSAV (Institute of Information Theory and Automation — Czechoslovak Academy of Sciences), Pod vodárenskou věží 4, 182 08 Praha 8, Czechoslovakia.